

SUBJECT:

SAFG3755 OVERLAP DOOR

INSTALLATION INSTRUCTION SHEET

WARNING: ELECTRICAL SHOCK POTENTIAL !! DO NOT ATTEMPT TO INSTALL, MAINTAIN OR RELAMP WITHOUT DIS-CONNECTING ALL POWER, FAILURE TO DISCONNECT POWER CAN RESULT IN ELECTROCUTION, SHOCK OR SEVERE BURNS. ONLY QUALIFIED PERSONNEL TO CONDUCT INSTALLATION.

CAUTION: INSTALL IN COMPLIANCE TO ALL APPLICABLE ELECTRICAL AND BUILDING CODES. INSTALLATION MUST BE PERFORMED BY QUALIFIED PERSONNEL.
***** SHOCK HAZARD. DISCONNECT ALL POWER BEFORE PERFORMING INSTALLATION *****

1. Disconnect mains power.
2. Open the fixture door frame by removing the four (12) 10-24 flathead screws. Disconnect the door frame aircraft cable from slot and safely put door aside.
3. Remove the palnuts to remove the cover.
4. Secure the fixture to ceiling grid at its intended location. Use any required additional mounting hardware (supplied by others) as required.
5. Ceiling and mounting hardware must be capable of supporting the full weight of the fixture and meet local building codes. Use hardware as specified by the architect.
6. Make wiring connections. Ensure the fixture is properly grounded to the fixture ground stud. A 7/8" Access hole is provide on fixture.
7. Re-attached the Cover. Add appropriate lamps.
8. Re-attached the door frame with its aircraft cable into slot on housing. Re-secure the door frame with the 10-24 flathead screws.
9. The Housing seals the top side of grid with a neoprene gasket. The door frame seals against the bottom side of grid with its own neoprene gasket.

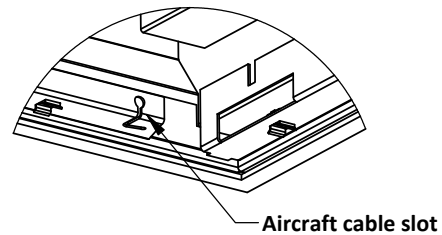
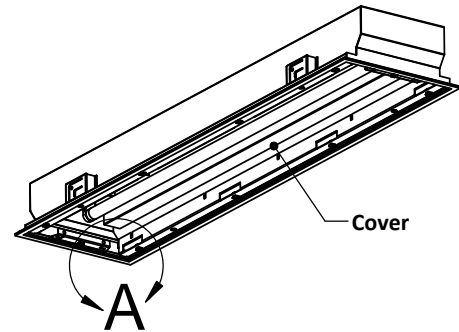
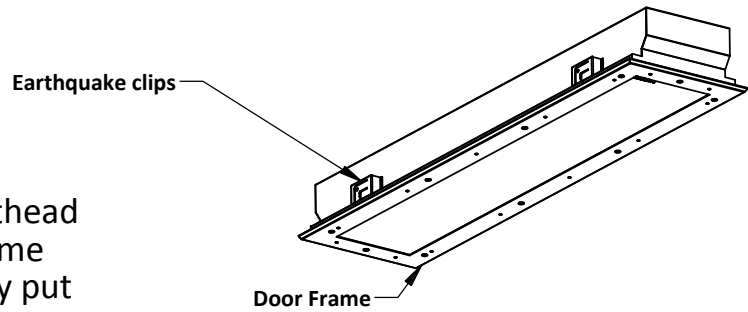

DETAIL A
SCALE 1 : 4

July 2014

SAFG3755 Overlap Door